

APPLIED MOTION TECHNOLOGIES, INC./ITTC

INDUSTRIAL FLUID POWER (IFP) PROGRAM

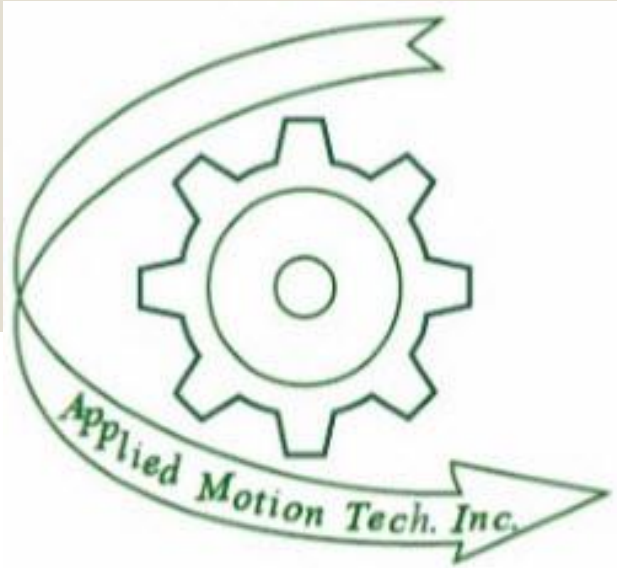

Providing industrial training since 1994



The Industrial Technology Training Center (ITTC) located at 625 Linden St. Bethlehem, PA

IFP Program Industrial Fluid Power

Our most requested training courses are the first three level courses offered by Applied Motion Technologies, Inc./ITTC – Getting Started with Hydraulics (GSH), Industrial Hydraulic Principles (IHP) and Hands on Hydraulics (HOH). The intent of these courses is to introduce students to hydraulic fluid power, components, circuits, capabilities, safety and applications. These courses are intended to develop depth of knowledge as students progress through each course. Because of the course’s integration and popularity, they have been combined into a comprehensive program – IFP.

ITTC – Industrial Technology Training Center

Applied Motion Technologies, Inc./ITTC (AMT) offers a unique, comfortable and well-equipped facility for a variety of industrial training needs. The above pictured main classroom is approximately 1,000 sq. feet complete with white boards, projectors, monitors and hands on components all around the room. Adjacent to this room is an additional 500 sq. foot classroom allowing for a second course to be offered within the same week.

Understanding that students often travel from out of state, AMT offers suggestions and assistance in local accommodations that are within walking distance to the training center or offer shuttle services – including to and from the local airport.

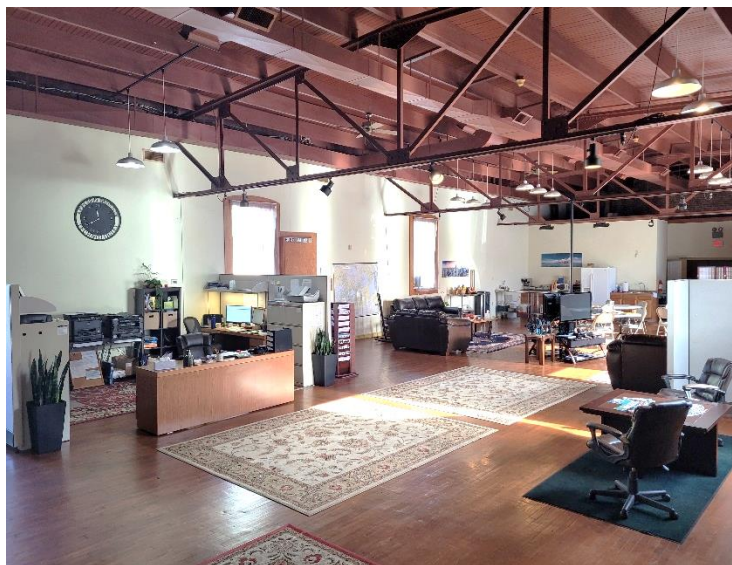

Student / employee lounge, break and meal area

The student lab offers seven test stand trainers allowing students to apply their classroom learning to hands on results and troubleshooting. (See the picture on page 2 of the student lab)

In addition to the student lab and classroom areas, the approximately 8,000 sq. foot training center has a back administrative office, full kitchen for food preparation and comfortable student lounge and meal area.



The student lab – test stand

TABLE OF CONTENTS

Introduction	Page 1
Program / Course description	Page 2
Admission requirements	Page 3
Tuition	Page 3
School Calendar	Page 3
Policies	Page 4
Grading	Page 4
Contact Information	Page 4

Industrial Fluid Power (IFP) Program

The IFP Program consists of three one-week courses (a total of 96 hours of training) that may be conveniently scheduled throughout the year to accommodate student’s work schedule availability. The program objective is intended to provide new and current employees within the hydraulic industry a comprehensive entry level understanding of hydraulic fluid power. The program allows both entry level employees/students to learn core competencies within this field, as well as provide expanded learning to existing employees in order to advance their knowledge and careers. This program helps to prepare individuals to become certified by the Industrial Fluid Power Society.

All three courses balance classroom instruction with actual hands on hydraulic circuits and components in our one-of-a-kind student lab featuring seven hydraulic test stands.



**GSH
Getting Started with Hydraulics**
One-week course (32 hours)

The US is undergoing the biggest turnover of its workforce in its history. Many of the newer American industrial maintenance workers are stepping into their positions with limited formal training or experience with hydraulic fluid power (industrial hydraulics). Attempting to read and interpret schematics, troubleshoot and maintain hydraulic-powered machines without any training can be a daunting task. This 5-day training course is the first step in the development of maintenance and technical personnel that need to understand their hydraulic powered and controlled equipment.

This first step hydraulic training course concentrates on developing students' understanding of industrial hydraulic fundamentals. These fundamentals include: characteristics of fluid pressure, fluid flow, fluid power, cylinder and hydraulic motor speed control and system heat production. Students will understand the purpose, function, operation and hydraulic schematic symbols for all major hydraulic valves and pumps. This training includes ample hands-on lab exercises to reinforce the classroom lecture. We want our students to come prepared to be challenged in the classroom and the lab.

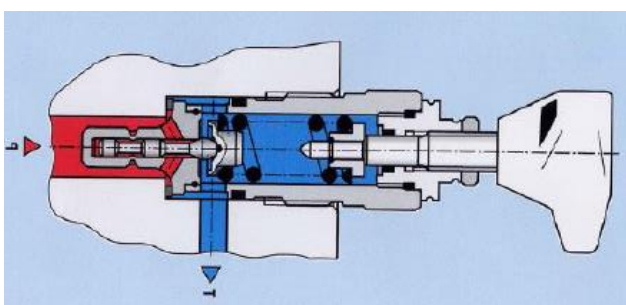

Pascal's Law
Page 10 #21

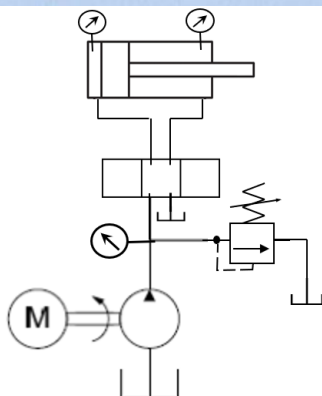

**IHP
Industrial Hydraulic Principles**
one week course (32 hours)

This is a 5-day training course that teaches maintenance personnel the principles of industrial hydraulics technology including basic calculations for fluid pressure and flow and actuator velocity/rpm. Starting with the practical ideas of force, area, pressure, fluid flow rate, cylinder speed, hydraulic motor speed, hydraulic power and hydraulic system heat production, students develop their understanding of how hydraulic powered and controlled machines work.

Students learn about all of the major groups of hydraulic components. They will review the function and principles of operation of direct operated and pilot operated relief valves, direct operated and pilot operated pressure reducing valves, direct operated and pilot operated directional control valves, check valves, pilot operated check valves, fixed displacement pumps, variable displacement pumps and accumulators.

Students develop their understanding of the 12 basic hydraulic circuits most often used in industrial hydraulic systems. These circuits are: system relief circuits, multiple system pressure relief circuits with low pressure vent, port relief (intensification relief) systems, cross port relief circuits, counterbalance circuits – with and without load holding P.O. checks, sequence circuits, high-low pump unloading circuits, load sensing circuits, pressure compensated variable displacements pumps with safety relief valves, regenerative systems and meter-in vs. meter-out speed control (throttle valve principle) and accumulators as auxiliary flow sources (accumulator safety blocks).

Additional time is devoted to teaching students how to 'read' and interpret hydraulic symbols. This is accomplished using special handouts of ISO standard symbol diagrams. There will be a brief introduction to the operation and application of electro-proportional hydraulic pressure and directional control valves with signals generated from a PLC.

This 5-day training course is approximately 50% lecture and 50% hands on lab exercises. The lab exercises reinforce the students understanding of hydraulic valve functions and of the hydraulic circuits previously listed.



**HOH
Hands On Hydraulics**
one week course (32 hours)

This final 5-day course completes the Industrial Fluid Power (IFP) Program. This course focuses on hydraulic valve and control circuits. This course offers more detailed learning and hands on training through self-directed labs.

Students will learn system relief valve troubleshooting including setup considerations for fixed displacement pumps, how to properly set a spike pressure relief valve when used with a pressure compensated variable displacement pump and how to evaluate hot running hydraulic systems. This course focuses in more detail on hydraulic pumps in comparison to the two previous courses. This includes determining why the hydraulic pump's electric drive motor shuts down on overload and troubleshooting worn pumps. Additionally, understanding and properly setting up a pressure compensated pump, a remote pressure compensated pump, a load sensing/meter in pressure compensated pump, and finally a horse power-controlled pump. This course emphasizes fluid cleanliness standards.

Students will be able to identify the difference between meter-in and meter out speed control and when meter-out speed control cannot be used. In depth discussions and learning are conducted on understanding stack valve systems by properly reading and interpreting a hydraulic schematic as well as properly assembling D03 stack valve systems according to a hydraulic schematic.

Students will learn how to properly check accumulator pre-charge pressure and add nitrogen to an accumulator. Students will setup a counterbalance circuit in the lab, learn the proper configuration of a hydraulic circuit when flow controls, counterbalance and load holding valves are all used to control the operation of a cylinder circuit. Students will understand the application of various directional control spool types.

Throughout this course and program completion, students will develop troubleshooting techniques and develop schematic reading and interpretation techniques.



ADMISSIONS

Admission Requirements and Procedures *Registration and Enrollment Form*

CONTACT JIM TRINKLE FOR MORE INFORMATION @ 610-704-2577

PRE-REQUISITES

(QUALIFICATIONS FOR ENROLLMENT)

Student will demonstrate through an enrollment-qualifying assessment that their reading skill level is equal to or better than 11th grade standard. Their reading level will be assessed using a standard recognized testing method. Successful completion of the Reading Assessment requires a score of 67% or a minimum of 20 out of 30 correct answers.

Students will demonstrate through an enrollment-qualifying assessment that their general mathematical skill level is equal to or better than 6th grade standard. Their mathematical level will be assessed using a standard recognized testing method. Successful completion of the Math Assessment requires a score of 67% or a minimum of 8 out of 12 correct answers.

The student must be 18 years of age or older on or before the commencement of the class. The student must have a high school diploma or GED equivalent.

Note: There is no reading or math assessment cost to an employer or to the student/applicant.

A completed Registration and Enrollment form is required prior to attendance.



Students sign in before each class in order to record attendance

TERMS OF PAYMENT

All tuition payments for the course(s) must be made prior to the beginning of classes.

CANCELLATION POLICY

A student may cancel their registration within 5 calendar days after signing the enrollment agreement. In the event of cancellation within 5 calendar days, the student will receive a full refund of all payments made to the school, including the registration fee.

If a student cancels more than 5 calendar days after signing the enrollment agreement but before classes start, the school will retain the \$150 registration fee. Any tuition payments are fully refundable if the student cancels prior to beginning the course.

TERMINATION DATE

The termination date for refund computation purposes is the last date of recorded attendance.

TUITION

IFP Program

The courses (GSH, IHP, HOH) when enrolled in the IFP Program are \$1,875 per student per course. The \$150 registration fee, books and supplies are included in tuition costs. This does not include any necessary travel or overnight accommodations.

The cumulative tuition is \$5,625. (\$150 registration fee + \$5,475 tuition)

Students may pay per course upon scheduling at an individual tuition cost of \$1,875 due upon the start of each respective course.

REFUND AND WITHDRAWAL POLICY

For a student completing up to and including 10% of the total clock hours, the school shall refund 90% of the total cost of the program.

For a student withdrawing from or discontinuing the program within the first 25% of the program, the tuition charges refunded by the school shall be at least 55% of the total cost of the program.

For a student withdrawing or discontinuing after 25% but within 50% of the program, the tuition charges refunded by the school shall be at least 30% of the total cost of the program.

For a student withdrawing or discontinuing after 50% of the program, the student is entitled to no refund.

An applicant rejected by the school is entitled to a refund of monies paid.

Refunds shall be made within 30-calendar days of the date the student fails to enter, leaves the program or fails to return from a leave of absence.

**Distance Education (Video Conferencing) is available per customer request
GSH-DE • IHP-DE • HOH-DE**

School / Course Calendar

GSH – Getting Started with Hydraulics

January 30 – February 3
April 3 – 7
June 26 – 30
August 14 – 18
October 30 – November 3

IHP – Industrial Hydraulic Principles

January 16 – 20
April 24 – 28
July 31 – August 4
October 2 – 6

HOH – Hands On Hydraulics

January 23 – 27
May 22 – 26
August 21 – 25
December 11 – 15

This is the initial course schedule for 2023. Based on enrollment and popularity, additional weeks may be added onto the schedule. This course schedule offers flexibility in program completion based on employer scheduling and a variety of weeks throughout the year. For current or amended school / course calendar dates, please visit the website at

www.amthydraulics.com

Policies

GRADING SYSTEM

The post-assessment (final test) is 100% of the student’s final grade and consists of 85% of the questions with five-part multiple choice answer possibilities and 15% true or false answer possibilities. The post-assessment (final test) has been created from as many as 33 of the most important learning points covered in the 32 hours of total student contact.

Successful completion of the course requires a grade of 70% or 23 correct answers. Successful completion is acknowledged as Level of Achievement and qualifies the student to move forward in the Industrial Fluid Power (IFP) Program if he/she desires to do so (prerequisites apply/see prerequisites). Students receiving a grade of less than 70% will receive an acknowledgement as Level of Completion.

Note: A one-time retest will be permitted. An AMT-designated person will be assigned to monitor the retest. This will be permitted for the student to raise his/her test score to 70% or more. Retesting will be scheduled as soon as possible and with consideration of the availability of the student and an AMT test monitor.

PROGRAM COMPLETION (GRADUATION)

A diploma will be awarded at the end of the IFP Program if students earn a Level of Achievement for each course (see image).

GSH – Getting Started with Hydraulics

IHP – Industrial Hydraulic Principles

HOH – Hands-On-Hydraulics

JOB PLACEMENT ASSISTANCE

THE SCHOOL DOES NOT GUARANTEE JOB PLACEMENT.

However, the school does provide services and support to assist students in obtaining employment. For employment relocation, background check, and drug screening may be necessary.

TRANSFER OF CREDIT DISCLAIMER

There is no guarantee that these training credits will transfer to another institution.



ATTENDANCE REQUIREMENTS

As the courses are only one week in length (32 hours each), attendance is mandatory for the course scheduled days/hours in order to fulfill the necessary instructional hours and covered material.

POLICY FOR MAKE-UP WORK

In the event that a student misses covered material due to illness, unavoidable travel delays or a family emergency, it shall be determined by the instructor if the lost time and the missed material is able to be covered within the week of the scheduled course (before or after course scheduled hours). If so, this will allow the student to complete the GSH course by the scheduled course end date. If the instructor determines that the missed work cannot be made up, arrangements must be made to reschedule the student’s attendance in another GSH class. AMT will work with the student as is practical and possible for the student to successfully complete each course.



INDUSTRIAL TECHNICAL TRAINING CENTER

CONTACT INFORMATION

Applied Motion Technologies, Inc.
625 Linden St. (ITTC/school)
Bethlehem, PA 18018
800-597-5677

(shipping)
1103 Harris Drive
Emmaus, PA 18049
610-704-2577

www.amthydraulics.com